

Automotive Grade Anti-Sulfurated Chip Resistor



Scope

- This specification applies to all sizes of rectangular-type fixed chip resistors with Ruthenium-base as material.

Features

- Special construction to prevent sulfuration in a sulfur containing environment
- AEC-Q200 Compliance

Construction

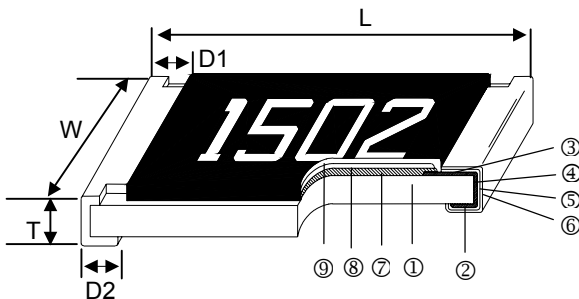

Applications

- Automotive
- High-end Computer
- Industrial Equipment
- Automatic Equipment Controller
- Medical Equipment
- High-end Multimedia Electronics
- Outdoor Electronic Applications

① Alumina Substrate	④ Edge Electrode (NiCr)	⑦ Resistor Layer (RuO ₂ /Ag)
② Bottom Electrode (Ag)	⑤ Barrier Layer (Ni)	⑧ Primary Overcoat (Glass)
③ Top Electrode (Ag-Pd)	⑥ External Electrode (Sn)	⑨ Secondary Overcoat (Epoxy)

Dimensions

Type	Size (Inch)	L (mm)	W (mm)	T (mm)	D1 (mm)	D2 (mm)	Weight (g) (1000pcs)
AS02	0402	1.00±0.05	0.50±0.05	0.35±0.05	0.20±0.10	0.20±0.10	0.620
AS03	0603	1.60±0.10	0.80±0.10	0.45±0.10	0.30±0.20	0.30±0.20	2.042
AS05	0805	2.00±0.10	1.25±0.10	0.50±0.10	0.35±0.20	0.40±0.20	4.368
AS06	1206	3.10±0.10	1.55±0.10	0.55±0.10	0.50±0.25	0.50±0.20	8.947
AS10	1210	3.10±0.10	2.60±0.15	0.55±0.10	0.50±0.25	0.50±0.20	15.959
AS0A	2010	5.00±0.10	2.50±0.15	0.55±0.10	0.60±0.25	0.50±0.20	24.241
AS12	2512	6.35±0.10	3.10±0.15	0.55±0.10	0.60±0.25	0.50±0.20	39.448

Part Numbering

AS	03	F	T	E	1002	A
Product Type	Dimensions	Resistance Tolerance	Packaging Code	TCR (PPM/C)	Resistance	Making
	02: 0402 03: 0603 05: 0805 06: 1206 10: 1210 0A: 2010 12: 2512	D: ±0.5% F: ±1% J: ±5%	B: Bulk T: Taping Reel	E: ±100 F: ±200	1000: 100Ω 1002: 10KΩ 2201: 2.2KΩ 1003: 100KΩ	: Standard A: Auto Grade

Recommend Land Pattern

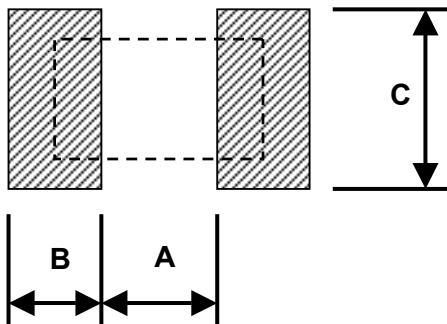

Derating Curve

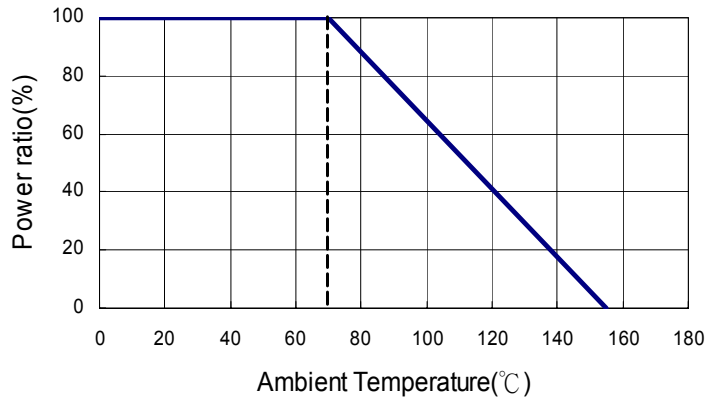

Type	A (mm)	B (mm)	C (mm)
AS02	0.50	0.45	0.60
AS03	0.90	0.60	0.90
AS05	1.20	0.70	1.30
AS06	2.00	0.90	1.60
AS10	2.00	0.90	2.80
AS0A	3.80	0.90	2.80
AS12	3.80	1.60	3.50

Soldering Condition

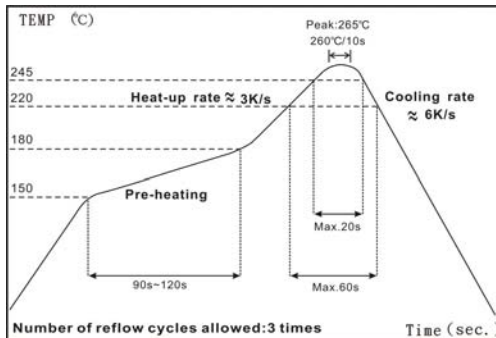

IR Reflow Soldering

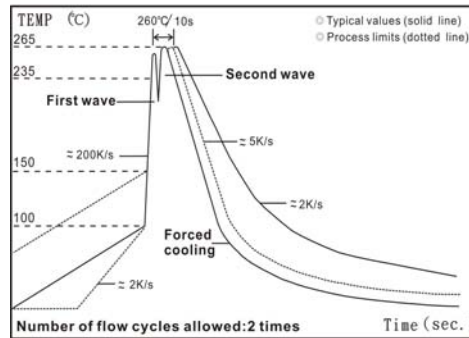

Wave Soldering (Flow Soldering)

- (1) Time of IR reflow soldering at maximum temperature point 260°C : 10s
- (2) Time of wave soldering at maximum temperature point 260°C : 10s
- (3) Time of soldering iron at maximum temperature point 410°C : 5s

Standard Electrical Specifications

Item Type	Power Rating at 70°C Jumper Rated Current	Operating Temp. Range	Max. Operating Voltage	Max. Overload Voltage	Resistance Range			TCR (PPM/°C)
					±0.5%	±1%	±5%	
AS02 (0402)	1/16W	-55 ~ +155°C	50V	100V	1Ω - 9.76Ω 10Ω - 1MΩ 1.02MΩ - 10MΩ			±200 ±100 ±200
	Jumper: 1A				0Ω (<50mΩ)			-
AS03 (0603)	1/10W		50V	100V	1Ω - 9.76Ω 10Ω - 1MΩ 1.02MΩ - 10MΩ			±200 ±100 ±200
	Jumper: 1A				0Ω (<50mΩ)			-
AS05 (0805)	1/8W		150V	300V	1Ω - 9.76Ω 10Ω - 1MΩ 1.02MΩ - 10MΩ			±200 ±100 ±200
	Jumper: 2A				0Ω (<50mΩ)			-
AS06 (1206)	1/4W		200V	400V	1Ω - 9.76Ω 10Ω - 1MΩ 1.02MΩ - 10MΩ			±200 ±100 ±200
	Jumper: 2A				0Ω (<50mΩ)			-
AS10 (1210)	1/3W		200V	400V	1Ω - 9.76Ω 10Ω - 1MΩ 1.02MΩ - 10MΩ			±200 ±100 ±200
	Jumper: 2.5A				0Ω (<50mΩ)			-
AS0A (2010)	3/4W		200V	400V	1Ω - 9.76Ω 10Ω - 1MΩ 1.02MΩ - 10MΩ			±200 ±100 ±200
	Jumper: 3.5A				0Ω (<50mΩ)			-
AS12 (2512)	1W	250V	500V	1Ω - 9.76Ω 10Ω - 1MΩ 1.02MΩ - 10MΩ			±200 ±100 ±200	
	Jumper: 4A			0Ω (<50mΩ)			-	

Operating Voltage= $\sqrt{P \cdot R}$ or Max. operating voltage listed above, whichever is lower.

Overload Voltage= $2.5 \cdot \sqrt{P \cdot R}$ or Max. overload voltage listed above, whichever is lower.

■ Viking is capable of manufacturing the optional spec based on customer's requirement.

■ Environmental Characteristics

Item	Requirement			Test Method
	1% and Below	5%	Jumper	
Temperature Coefficient of Resistance (T.C.R.)	As Spec.			JIS C 5201-1 4.8 IEC 60115-1 4.8 -55°C~+125°C, 25°C is the reference temperature
Short Time Overload	±(1.0%+0.05Ω)	±(2.0%+0.05Ω)	<50mΩ	JIS C 5201-1 4.13 IEC 60115-1 4.13 2.5 times RCWV or Max. Overload voltage whichever is lower for 5 seconds
Insulation Resistance	≥ 10G			JIS C 5201-1 4.6 IEC 60115-1 4.6 Max. Overload voltage for 1 minute
Endurance	±(2.0%+0.10Ω)	±(3.0%+0.10Ω)	<100mΩ	JIS C 5201-1 4.25 IEC 60115-1 4.25.1 70±2°C, RCWV for 1000 hrs with 1.5 hrs "ON" and 0.5 hrs "OFF"
Biased Humidity	±(2.0%+0.10Ω)	±(3.0%+0.10Ω)	<100mΩ	MIL-STD-202 Method 103 1000 hrs 85°C/85%RH 10% of operating power.
High Temperature Exposure	±(1.0%+0.05Ω)	±(1.5%+0.10Ω)	<50mΩ	MIL-STD-202 Method 108 at +155°C for 1000 hrs
Bending Strength	±(1.0%+0.05Ω)	±(1.0%+0.05Ω)	<50mΩ	JIS C 5201-1 4.33 IEC 60115-1 4.33 Bending once for 5 seconds 2010, 2512 sizes: 2 mm Other sizes: 3mm
Thermal Shock	±(0.5%+0.05Ω)	±(1.0%+0.05Ω)	<50mΩ	MIL-STD-202 Method 107 -55C/+155°C. Note: Number of cycles required-300, Maximum transfer time-20 seconds, Dwell time-15minutes. Air-Air.
Solderability	>95% coverage			JIS C 5201-1 4.17 IEC 60115-1 4.17 245±5°C for 3 seconds
Resistance to Soldering Heat	±(0.5%+0.05Ω)	±(1.0%+0.05Ω)	<50mΩ	JIS C 5201-1 4.18 IEC 60115-1 4.18 260±5°C for 10 seconds
Voltage Proof	No breakdown or flashover			JIS C 5201-1 4.7 IEC 60115-1 4.7 1.42 times Max. Operating Voltage for 1 minute
Leaching	Individual leaching area ≤5% Total leaching area ≤10%			JIS C 5201-1 4.18 IEC 60068-2-58 8.2.1 260±5°C for 30 seconds
Temperature Cycling	±(0.5%+0.05Ω)	±(1.5%+0.05Ω)	<50mΩ	JESD22 Method JA-104 -55°C to +125°C, 1000 cycles
Moisture Resistance	±(2.0%+0.05Ω)	±(3.0%+0.05Ω)	<50mΩ	MIL-STD-202 Method 106 24 hrs/cycle
Mechanical Shock	±(0.25%+0.05Ω)	±(1.0%+0.05Ω)	<50mΩ	MIL-STD-202 Method 213 Wave Form: Tolerance for half sine shock pulse. Peak value is 100g's. Normal duration (D) is 6.

Automotive Grade Anti-Sulfurated Chip Resistor

Item	Requirement			Test Method
	1% and Below	5%	Jumper	
Vibration	$\pm(0.5\%+0.05\Omega)$	$\pm(1.0\%+0.05\Omega)$	<50m Ω	MIL-STD-202 Method 204 5 g's for 20 min., 12 cycles each of 3 orientations, 10-2000 Hz
ESD	$\pm(1\%+0.05\Omega)$			AEC-Q200-002 Human body, 2KV
Flame Retardance	Not flame			AEC-Q200-001 Temperature sensing at 500 °C , voltage power subjected to 32VDC current clamped up to 500ADC and decreased in 1.0VDC/hour.
Resistance to solvents	Marking Unsmearred			MIL-STD-202 Method 215 Add Aqueous wash chemical - OKEM Clean or equivalent. Do not use banned solvents.
Terminal strength	No broken			AEC-Q200-006 Force of 1.8kg for 60 seconds.
Flammability	No ignition of the tissue paper or scorching or the pinewood board			UL-94 V-0 or V-1 are acceptable. Electrical test not required.
Sulfur Test	$\Delta R \pm 0.5\%$		<50m Ω	ASTM-B-809-95 3~5ppm H ₂ S, 50 \pm 2°C, 91~93% R.H., no power rating for 1000 hrs

RCWV(Rated continuous working voltage)= $\sqrt{P \cdot R}$ or Max. Operating voltage whichever is lower.

■ **Storage Temperature: 25 \pm 3°C; Humidity < 80%RH**

■ **Packaging**

Reel Specifications & Packaging Quantity

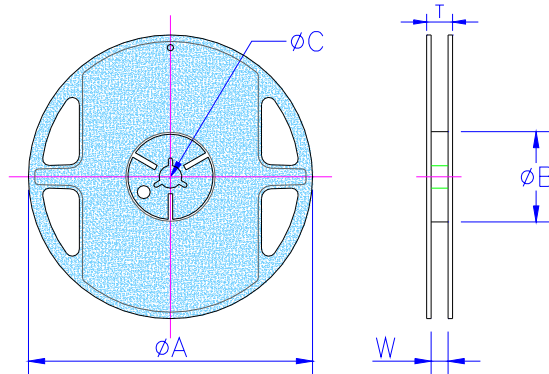

Type	Packaging Quantity		Tape Width	Reel Diameter	ΦA (mm)	ΦB (mm)	ΦC (mm)	W (mm)	T (mm)
AS02	Paper	10K	8mm	7 inch	178.5 \pm 1.5	60 ^{+1/-0}	13.0 \pm 0.2	9.0 \pm 0.5	12.5 \pm 0.5
AS03 AS05 AS06 AS10	Paper	5K	8mm	7 inch	178.5 \pm 1.5	60 ^{+1/-0}	13.0 \pm 0.2	9.0 \pm 0.5	12.5 \pm 0.5
AS0A AS12	Embossed	4K	12mm	7 inch	178.5 \pm 1.5	60 ^{+1/-0}	13.0 \pm 0.5	13.0 \pm 0.5	15.5 \pm 0.5

Paper Tape Specifications

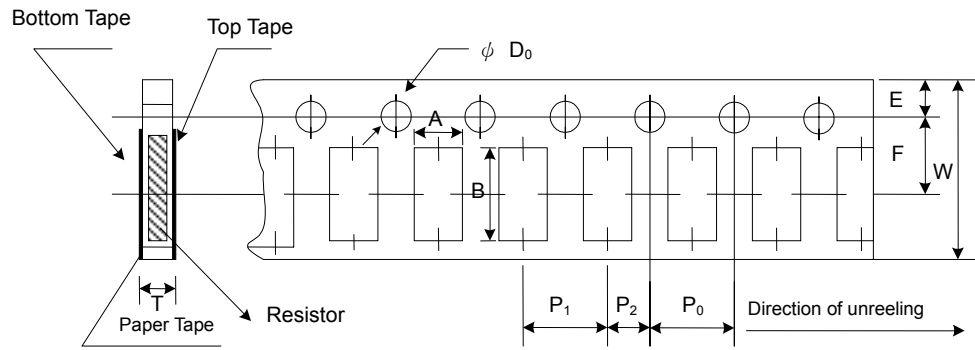

Type	A (mm)	B (mm)	W (mm)	E (mm)	F (mm)	P ₀ (mm)	P ₁ (mm)	P ₂ (mm)	ΦD ₀ (mm)	T (mm)
AS02	0.65±0.10	1.15±0.10	8.0±0.20	1.75±0.10	3.50±0.05	4.00±0.10	2.00±0.05	2.00±0.05	1.50+0.1,-0	0.45±0.10
AS03	1.10±0.10	1.90±0.10	8.0±0.20	1.75±0.10	3.50±0.05	4.00±0.10	4.00±0.05	2.00±0.05	1.50+0.1,-0	0.70±0.10
AS05	1.60±0.10	2.40±0.20	8.0±0.20	1.75±0.10	3.50±0.05	4.00±0.10	4.00±0.05	2.00±0.05	1.50+0.1,-0	0.85±0.10
AS06	1.90±0.10	3.50±0.20	8.0±0.20	1.75±0.10	3.50±0.05	4.00±0.10	4.00±0.05	2.00±0.05	1.50+0.1,-0	0.85±0.10
AS10	2.90±0.10	3.50±0.20	8.0±0.20	1.75±0.10	3.50±0.05	4.00±0.10	4.00±0.05	2.00±0.05	1.50+0.1,-0	0.85±0.10

Embossed Plastic Tape Specifications

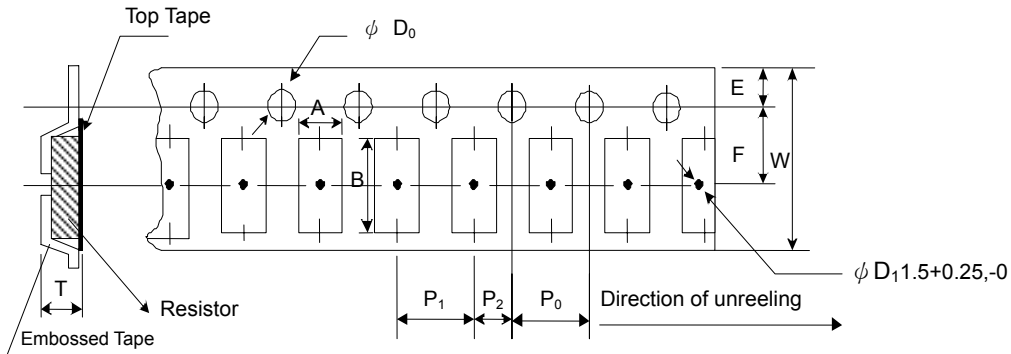

Type	A (mm)	B (mm)	W (mm)	E (mm)	F (mm)	P ₀ (mm)	P ₁ (mm)	P ₂ (mm)	ΦD ₀ (mm)	T (mm)
AS0A	2.8±0.10	5.5±0.10	12.0±0.30	1.75±0.10	5.5±0.05	4.00±0.10	4.00±0.10	2.00±0.05	1.50+0.1, -0	1.2 ⁺⁰
AS12	3.5±0.10	6.7±0.10	12.0±0.30	1.75±0.10	5.5±0.05	4.00±0.10	4.00±0.10	2.00±0.05	1.50+0.1, -0	1.2 ⁺⁰

■ Marking

No Marking for 0402

Jumper for all: Letter "0"

1% for 0805/1206/1210/2010/2512: 4 digits marking

Example:

Resistance	100Ω	2.2KΩ	10KΩ	49.9KΩ	100KΩ
Marking	1000	2201	1002	4992	1003

5% for 0603/0805/1206/1210/2010/2512: 3 digits marking in E24

Example: 101=100Ω 102=1KΩ (1st and 2nd are E24 code and 3rd code is multiplier)

E24 code	10	11	12	13	15	16	18	20	22	24	27	30	33	36	39	43	47	51	56	62	68	75	82	91
----------	----	----	----	----	----	----	----	----	----	----	----	----	----	----	----	----	----	----	----	----	----	----	----	----

1% for 0603: 3 digits marking in E96



3 digits marking for Example: 14C=13K7Ω 13C=13K3Ω
68B=4K99Ω 68X=49.9Ω

Marking Table

Code	E96	Code	E96	Code	E96	Code	E96				
01	100	25	178	49	316	73	562				
02	102	26	182	50	324	74	576				
03	105	27	187	51	332	75	590				
04	107	28	191	52	340	76	604				
05	110	29	196	53	348	77	619				
06	113	30	200	54	357	78	634				
07	115	31	205	55	365	79	649				
08	118	32	210	56	374	80	665				
09	121	33	215	57	383	81	681				
10	124	34	221	58	392	82	698				
11	127	35	226	59	402	83	715				
12	130	36	232	60	412	84	732				
13	133	37	237	61	422	85	750				
14	137	38	243	62	432	86	768				
15	140	39	249	63	442	87	787				
16	143	40	255	64	453	88	806				
17	147	41	261	65	464	89	825				
18	150	42	267	66	475	90	845				
19	154	43	274	67	487	91	866				
20	158	44	280	68	499	92	887				
21	162	45	287	69	511	93	909				
22	165	46	294	70	523	94	931				
23	169	47	301	71	536	95	953				
24	174	48	309	72	549	96	976				
Code	A	B	C	D	E	F	G	X	Y		
Multiplier	10 ⁰	10 ¹	10 ²	10 ³	10 ⁴	10 ⁵	10 ⁶	10 ⁻¹	10 ⁻²		